

## 10:1 Fire-Ball<sup>®</sup> 425 Pump

308655J

**For pumping non-corrosive and non-abrasive oils and lubricants only.**

*180 psi (12.4 bar) Maximum Incoming Air Pressure  
1800 psi (124 bar) Maximum Fluid Working Pressure*

**Model 205626, Series K**

*Universal Pump*

**Model 222065, Series C**

*55-Gallon Drum Cover-Mount Pump*

**Model 222095, Series C**

*55-Gallon Drum Bung-Mount Pump*



**Important Safety Instructions.**

Read all warnings and instructions in this manual.  
Save these instructions.

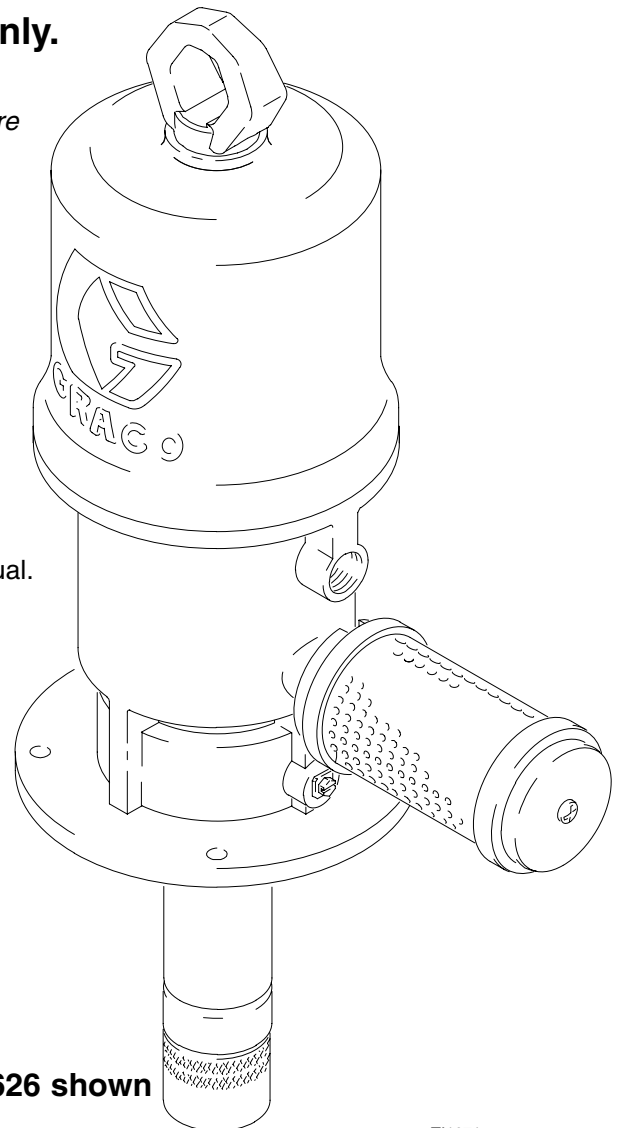

**Model 205626 shown**

TI1071

**PROVEN QUALITY. LEADING TECHNOLOGY.**

# Table of Contents

Warnings .....	2	Parts Drawing .....	15
Installation .....	4	Dimensions .....	16
Operation .....	7	Mounting Hole Layout .....	16
Troubleshooting .....	8	Technical Data .....	16
Air Motor and Throat Service .....	9	Performance Chart .....	17
Displacement Pump Service .....	13	Warranty .....	18
Parts List .....	14	Graco Phone Number .....	18

## Symbols

### Warning Symbol



This symbol alerts you to the possibility of serious injury or death if you do not follow the instructions.

### Caution Symbol



This symbol alerts you to the possibility of damage to or destruction of equipment if you do not follow the instructions.

**WARNING**

 <b>INSTRUCTIONS</b>	<p><b>EQUIPMENT MISUSE HAZARD</b></p> <p>Equipment misuse can cause the equipment to rupture or malfunction and result in serious injury.</p> <ul style="list-style-type: none"> <li>● This equipment is for professional use only.</li> <li>● Read all instruction manuals, tags, and labels before you operate this equipment.</li> <li>● Use the equipment only for its intended purpose. If you are not sure, call your Graco distributor.</li> <li>● Do not alter or modify this equipment.</li> <li>● Check equipment daily. Repair or replace worn or damaged parts immediately.</li> <li>● Do not exceed the maximum working pressure stated on the equipment or in the <b>Technical Data</b> for your equipment. Do not exceed the maximum working pressure of the lowest rated component in your system.</li> <li>● Use fluids and solvents which are compatible with the equipment wetted parts. Refer to the <b>Technical Data</b> section of all equipment manuals. Read the fluid and solvent manufacturer's warnings.</li> <li>● Do not use 1,1,1-trichloroethane, methylene chloride, other halogenated hydrocarbon solvents or fluids that contain such solvents in pressurized aluminum equipment. Such use could result in a chemical reaction, with the possibility of explosion.</li> <li>● Handle hoses carefully. Do not pull on hoses to move equipment.</li> <li>● Route hoses away from traffic areas, sharp edges, moving parts, and hot surfaces. Do not expose Graco hoses to temperatures above 82°C (180°F) or below -40°C (-40°F).</li> <li>● Do not lift pressurized equipment.</li> <li>● Comply with all applicable local, state, and national fire, electrical, and safety regulations.</li> </ul>
-------------------------	--

# ! WARNING



## SKIN INJECTION HAZARD

Fluid from the dispensing valve, leaks, or ruptured components can inject fluid into your body and cause extremely serious injury, including the need for amputation. Fluid splashed in the eyes or on the skin can also cause serious injury.

- Fluid injected into the skin may look like just a cut, but it is a serious injury. **Get immediate surgical treatment.**
- Do not point the dispensing valve at anyone or at any part of the body.
- Do not put your hand or fingers over the end of the dispensing valve.
- Do not stop or deflect leaks with your hand, body, glove or rag.
- Use only extensions and no-drip tips that are designed for use with your dispensing valve.
- Tighten all fluid connections before you operate this equipment.
- Check the hoses, tubes, and couplings daily. Replace worn or damaged parts immediately. Do not repair high pressure couplings; you must replace the entire hose.



## HAZARDOUS FLUIDS

Improper handling of hazardous fluids or inhaling toxic fumes can cause extremely serious injury, even death, due to splashing in the eyes, ingestion, or bodily contamination.

- Know the specific hazards of the fluid you are using.
- Store hazardous fluid in an approved container. Dispose of hazardous fluid according to all local, state, and national guidelines.
- Always wear protective eyewear, gloves, clothing, and respirator as recommended by the fluid and solvent manufacturer.



## FIRE AND EXPLOSION HAZARD

Improper grounding, poor ventilation, open flames or sparks can cause a hazardous condition and result in a fire or explosion and serious injury.

- Ground the equipment. Refer to **Grounding** on page 6.
- If there is any static sparking or you feel an electric shock while you use this equipment, **stop dispensing immediately**. Do not use the equipment until you identify and correct the problem.
- Provide fresh air ventilation to avoid the buildup of flammable fumes from solvents or the fluid being dispensed.
- Do not smoke in the dispensing area.



## MOVING PARTS HAZARD

Moving parts can pinch or amputate your fingers.

- Keep clear of all moving parts when you start or operate the pump.
- Before you service this equipment, follow the **Pressure Relief Procedure** on page 7 to prevent the equipment from starting unexpectedly.

# Installation

The typical installation shown in Fig.1 is only a guide to help you select and install a pump; it is not an actual system design. Contact your Graco distributor for assistance in designing a system to suit your needs.

## CAUTION

Always mount the pump firmly to a bracket or a tank cover. Never operate the pump while it is not mounted. Such use could damage the pump and fittings.

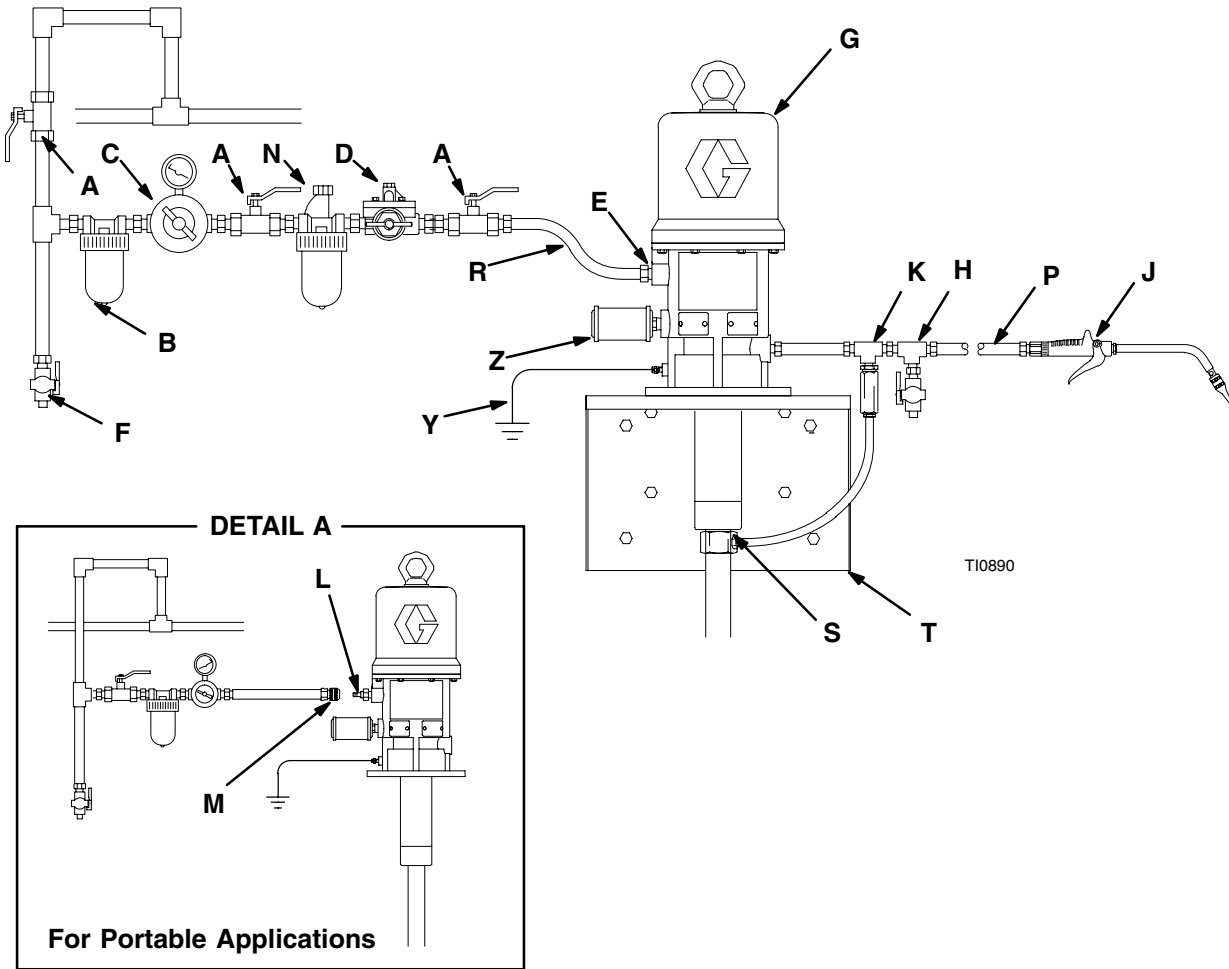

### KEY

- |   |  |
|---|--|
| <p><b>A</b> Bleed-type master air valve<br/><i>(required, Part No. 107142)</i></p> <p><b>B</b> Air line filter</p> <p><b>C</b> Air regulator and gauge</p> <p><b>D</b> Pump runaway valve</p> <p><b>E</b> Air inlet</p> <p><b>F</b> Ball valve <i>(for releasing collected moisture)</i></p> <p><b>G</b> Pump</p> <p><b>H</b> Drain valve <i>(required, Part No. 210658)</i></p> <p><b>J</b> Dispensing valve <i>(model 222411 shown)</i></p> <p><b>K</b> Thermal relief kit <i>(required, Part No. 240429)</i></p> | <p><b>L</b> Male quick-disconnect fitting</p> <p><b>M</b> Female quick-disconnect coupler</p> <p><b>N</b> Air line lubricator</p> <p><b>P</b> Fluid hose</p> <p><b>R</b> Electrically conductive air hose <i>(218093 shown)</i><br/><i>Use at least 1/2 in. (13 mm) ID to supply an adequate volume of air to the air motor.</i></p> <p><b>S</b> Fluid inlet</p> <p><b>T</b> Wall-mounting bracket <i>(Part No. 238245)</i></p> <p><b>Y</b> Ground wire <i>(required, Part No. 222011)</i></p> <p><b>Z</b> Muffler</p> |
|---|--|

Fig. 1

06038

# Installation

## System Accessories

### CAUTION

Do not hang the air accessories directly on the air inlet (E). The fittings are not strong enough to support the accessories and may cause one or more to break. Provide a bracket on which to mount the accessories.

**NOTE:** Install the following accessories in the order shown in Fig. 1.

### WARNING

Four accessories are **required** in your system: an air shut-off valve/air bleed device, fluid drain valve, thermal relief kit, and ground wire. These accessories help reduce the risk of serious bodily injury including fluid injection, splashing in the eyes or on the skin, injury from moving parts if you are adjusting or repairing the pump, and explosion from static sparking.

The air bleed device relieves air trapped between it and the air motor after the air supply is shut off. Trapped air can cause the air motor to cycle unexpectedly, causing serious bodily injury if you are adjusting or repairing the pump. Use either a bleed-type master air valve (A) or a quick-disconnect coupler (M) and fitting (L). Install near the pump air inlet, within easy reach of the pump.

The fluid drain valve (H) assists in relieving fluid pressure in the displacement pump, hoses, and dispensing valve. Triggering the valve to relieve pressure may not be sufficient.

The thermal relief kit assists in relieving pressure in the pump, hose, and dispensing valve due to heat expansion.

The ground wire reduces the risk of static sparking.

- Screw the muffler (5) into the 3/4-in. npt muffler port, and tighten it using a wrench on the flats of the muffler near the male threads.
- Install an air line lubricator (N) for automatic air motor lubrication.
- Install the air regulator (C) to control pump speed and pressure.

- Install an air line filter (B) to remove harmful dirt and contaminants from your compressed air supply.

- Install a bleed-type master air valve (A) to isolate the accessories for servicing. See Fig. 1. *To order a bleed-type master air valve, order Part No. 107142.*

As an alternative to a bleed-type master air valve, you can install an air line quick disconnect coupler (M) and fitting (L) to serve as an air-bleed device. See Detail A in Fig. 1.

- Install a ball valve (F), at the end of a line drop, as shown in Fig. 1, for releasing moisture that collects in the line.
- Install a drain valve (H) near the pump fluid outlet to relieve fluid pressure in the hoses and gun when opened. *To order a fluid drain valve, order Part No. 210658.*
- Install a pump runaway valve (D) to shut off the air to the pump if the pump accelerates beyond the pre-adjusted setting, which can be caused by a depleted fluid supply. A pump that runs too fast can be seriously damaged. *To order a 3/4-in. npt(f) inlet and outlet pump runaway valve, order Part No. 215362.*
- Install a thermal relief kit (K) on the dispensing valve side of the pump. *To order a 1600 psi (110 bar) thermal relief kit, order Part No. 240429.*
- Install a suitable fluid hose (P) and dispensing valve (J).

### Wall Mount

The pump shown in Fig. 1 is a wall-mounted universal pump, Model 205626. To order the wall-mounting bracket shown, order Part No. 238245.

### Cover Mount

Pump Model 222065 is designed for mounting directly on a 55-gallon drum cover. When the pump is mounted to a closed-head drum, be sure you loosen the vent plug on the drum cover to prevent a vacuum in the drum. For cover mounting, see the **Mounting Hole Layout** on page 16.

### Bung Mount

Pump model 222095 is designed for bung mounting on a 55-gallon drum. The bung adapter (153) is shown in the **Parts Drawing** on page 15.

# Installation

## Grounding

Proper grounding is an essential part of maintaining a safe system.

To reduce the risk of static sparking, ground the pump. Check your local electrical code for detailed grounding instructions for your area and type of equipment. Be sure to ground this equipment:

- *Pump:* Use a ground wire and clamp as shown in Fig. 2.
- *Air and Fluid hoses:* Use only electrically conductive hoses.
- *Air compressor:* Follow the manufacturer's recommendations.
- *Fluid supply container:* Follow the local code.
- *Object being lubricated:* Follow the local code.
- *To maintain grounding continuity when flushing or relieving pressure,* always hold a metal part of the valve firmly to the side of a grounded metal pail, then trigger the valve.

**To ground the pump,** remove the ground screw (Z) and insert through the eye of the ring terminal at end of the ground wire (Y). Fasten the ground screw back onto the pump and tighten securely. Connect the other end of the ground wire to a true earth ground. See Fig. 2. *To order a ground wire and clamp, order Part No. 222011.*

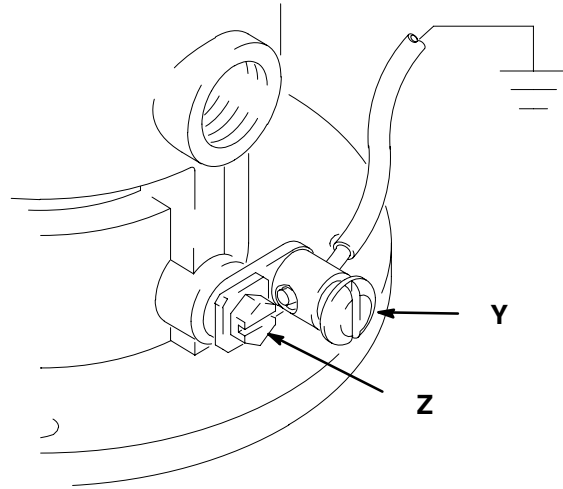

**Fig. 2**

TI1052

# Operation

## Pressure Relief Procedure

### WARNING



#### SKIN INJECTION HAZARD

To reduce the risk of serious bodily injury, including fluid injection or splashing in the eyes or on the skin,

always follow this procedure whenever you shut off the pump, check or service any part of the system, install or change dispensing devices, and when you stop dispensing.

1. Close the bleed-type master air valve (required in your system).
2. Hold a metal part of the dispensing valve firmly to a grounded metal waste container, and trigger the valve to relieve the fluid pressure, or open the drain valve (H).

*If you suspect that the nozzle or hose is completely clogged, or that pressure has not been fully relieved after you have followed the steps above, do the following: Wrap a rag around the hose end coupling, and relieve pressure gradually by **very slowly** partially loosening the fitting. Then loosen completely, then clear the obstruction.*

## Startup and Adjustment

### WARNING



#### COMPONENT RUPTURE HAZARD

The maximum working pressure of each component in the system may not be the same. To reduce the risk of overpressurizing any component in the system, be sure you know the maximum working pressure of each component, including the air motor and pump.

**Never** exceed the maximum working pressure of the lowest rated component in the system. Overpressurizing any component can result in rupture, fire, explosion, property damage, and serious injury.

To determine the fluid output pressure using the air regulator reading, multiply the ratio of the pump by the air pressure shown on the regulator gauge. For example:

$$10 \text{ (:1) ratio} \times 180 \text{ psi air} = 1800 \text{ psi fluid output}$$

$$[10 \text{ (:1) ratio} \times 12.4 \text{ bar air} = 124 \text{ bar fluid output}]$$

Limit the air to the pump so that no air line or fluid line component or accessory is overpressurized.

### WARNING

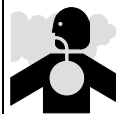

#### HAZARDOUS VAPORS

The air motor exhaust coming out of the muffler could contain harmful materials, such as oil, antifreeze, or some of the material being pumped.

### WARNING



#### MOVING PARTS HAZARD

Do not operate the pump without the muffler installed. When the muffler is not installed, the air motor is exposed, and it could cut your fingers if they are pushed into the muffler opening.

1. With the air regulator (C) closed, open the bleed-type master air valves (A) or, if so equipped, join the quick disconnect coupler (M) to the male fitting (L).
2. Open the dispensing valve (J) into a grounded metal waste container, making firm metal-to-metal contact between the container and valve.
3. Open the pump air regulator (C) slowly, just until the pump is running. When the pump is primed and all air has been pushed out of the lines, close the dispensing valve.

**NOTE:** When the pump is primed, and with sufficient air supplied, the pump starts when the dispensing valve is opened and shuts off when it is closed.

4. If your system is equipped with a runaway valve (D in Fig. 1), set it for your system configuration. See manual 308201 for instructions on setting the pump runaway valve.
5. Adjust the air regulator until you get sufficient flow from the dispensing valve. Always run the pump at the lowest speed necessary to get the desired results. Do not exceed the maximum working pressure of any component in the system.
6. If your pump accelerates quickly or is running too fast, stop it immediately, and check the fluid supply. If the supply container is empty and air has been pumped into the lines, prime the pump and lines with fluid, or flush it and leave it filled with a compatible solvent. Be sure to eliminate all air from the fluid lines. If your system has a runaway valve, reset it according to the instructions in manual 308201.

# Operation

## ⚠ CAUTION

Never allow the pump to run dry of the fluid being pumped. A dry pump will quickly accelerate to a high speed, possibly damaging itself, and it may get very hot.

- If the pump will be unattended for any period of time, if there is an air supply interruption, or to shut off the system at the end of the work shift, **always relieve the pressure.**

## ⚠ WARNING

To reduce the risk of serious injury whenever you are instructed to relieve pressure, always follow the **Pressure Relief Procedure** on page 7.

- Read and follow the instructions supplied with each component in your system.
- Check periodically to ensure that the pump's mounting is secure.

# Troubleshooting

## ⚠ WARNING



### SKIN INJECTION HAZARD

To reduce the risk of serious bodily injury, including fluid injection or splashing in the eyes or on the skin, always follow the **Pressure Relief Procedure** on page 7 when you shut off the pump, check or service any part of the system, install or change dispensing devices, and when you stop dispensing.

**NOTE:** Check all other possible problems and solutions before you disassemble the pump.

Problem	Cause	Solution
Pump fails to operate, or there is no fluid flow.	Inadequate air supply pressure or restricted air lines	Increase air supply; clear
	Closed or clogged dispensing valve	Open; clear
	Clogged fluid lines, hoses, valves, etc.	Clear*
	Damaged air motor	Service air motor
	Exhausted fluid supply	Refill and reprime or flush
Continuous air exhaust	Worn or damaged air motor gasket, packing, seal, etc.	Service air motor
Erratic pump operation	Exhausted fluid supply	Refill and reprime or flush
	Held open or worn intake valve or piston packings	Clear; service
Pump operates, but output low on up stroke	Held open or worn piston packings	Clear; service
Pump operates, but output low on down stroke	Held open or worn intake valve	Clear; service
Pump operates, but output low on both strokes	Inadequate air supply pressure or restricted air lines	Increase air supply; clear
	Closed or clogged valves	Open; clear
Fluid is coming out of the muffler.	Worn or damaged throat seal	Service

\* Follow the **Pressure Relief Procedure** on page 7, and disconnect the fluid line. If the pump starts when the air is turned on again, the line, hose, valve, etc., is clogged.

# Air Motor and Throat Service

## Before You Start

- Be sure you have all necessary parts on hand. **Repair Kit 238751** includes repair parts for the air motor and pump. Use all parts in the kit for the best results. Parts included in the kit are marked with one asterisk, for example (19\*), in the text and drawings. See the **Parts List** on page 14.
- Two accessory tools should be used: **Padded Pliers, 207579**, are used to grip the trip rod without damaging its surface, and a **0.125-in. (3.18 mm) Gauge, 171818**, is used to assure the proper clearance between the poppets and seat of the piston.

## Disassembly

1. Flush the pump.

### **⚠ WARNING**

To reduce the risk of serious injury whenever you are instructed to relieve pressure, always follow the **Pressure Relief Procedure** on page 7.

2. **Relieve the pressure.**
3. Disconnect the hoses, remove the pump from its mounting, and clamp the air motor base (28) in a vise horizontally by closing the vise jaws on the flange.
4. Use a strap wrench on the displacement pump cylinder (110) to screw it out of the air motor base (28). See Fig. 3.
5. Remove the piston/valve seat (109) from the displacement rod (29) with wrenches or with the vise and a wrench.
6. Remove the piston ball (103), seal (107\*), and seal retainer washer (113).
7. Remove the air motor base from the vise, and place the displacement rod (29) flats in the vise with the air motor up.
8. Loosen the lift ring (24). Pull up the lift ring, grip the trip rod (31) with the padded pliers, and screw the lift ring off of the rod.

### **⚠ CAUTION**

Do not damage the plated surface of the trip rod (31). Damaging the surface of the trip rod can result in erratic air motor operation. Use the special padded pliers, 207579, to grasp the rod.

9. Remove the eight screws (3) that hold the cylinder (30) to the base (28). Carefully pull the cylinder straight up off of the piston assembly (27).

### **⚠ CAUTION**

To avoid damaging the cylinder wall, lift the cylinder straight up off of the piston. Never tilt the cylinder as it is being removed.

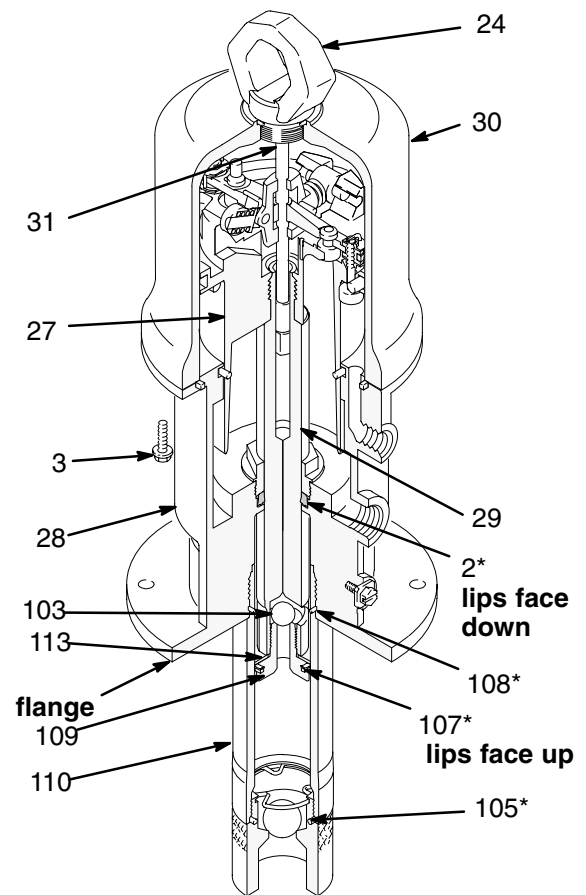

**Fig. 3**

T11072

\* Included in Pump Repair Kit 238751, which may be purchased separately.

# Air Motor and Throat Service

10. Pull the piston assembly (27) from the air motor base (28), and set it aside.
11. Remove the throat bearing (36) with a 1 5/8-in. socket, remove the seal (2\*), and wipe the seat clean with a cloth.
12. Remove the piston/base assembly from the vise, and set it upright on the workbench.
13. Inspect the air motor for damaged or worn lower valve grommets (17\*), o-rings (19\*, 20\*), valve nuts (21\*), lock wires (22\*), exhaust valve poppets (26\*), and inlet valve poppets (32\*). If any of these parts need to be replaced, continue with steps 14 to 20. Otherwise, see **Reassembly** on page 11.
14. Use a screwdriver to push down on the trip rod yoke (13), and snap the toggles down. See Fig. 4.
15. *In this step, while you are prying with the screwdriver with one hand, cover the toggle assemblies with your other hand so as to catch the spring-loaded toggle assemblies when they snap out of the lugs.* Place the tip of a screwdriver into the piston between the piston lugs (L) below the pivot pins (16) on the toggles, pry up with the screwdriver handle to compress the springs on the toggle assembly (M) up and away from the piston lugs, and remove the parts. See Fig. 4.
16. Straighten the lockwires (22\*), and remove them from the valve nuts (21\*). Screw the top nuts off. Remove the trip rod yoke (13), actuator (12), and trip rod (31). Unscrew the bottom valve nuts (21\*), and remove the poppets inlet valve poppets (32\*). Make sure the valve bar spring clips (14) are not worn or damaged and that they properly guide the actuator.
17. Remove the exhaust valve poppets (26) by cutting them with a side cutter, then pull them out of the actuator (12).
18. Clean all the parts carefully in a compatible solvent, and inspect them for wear or damage. Use all the repair kit parts during reassembly, and replace other parts as necessary.
19. Check the surfaces of the air motor piston (27), displacement rod (29), and the wall of the air motor cylinder (30) for scoring or scratches. Scored or scratched surfaces cause premature packing wear and leaking.
20. Lubricate all parts with a light, waterproof grease.

## **WARNING**



### **MOVING PARTS HAZARD**

To reduce the risk of pinching or amputating your fingers, keep your fingers clear of the toggle assemblies when you are snapping the toggles

(M in Fig. 4 ) up or down.

# Air Motor and Throat Service

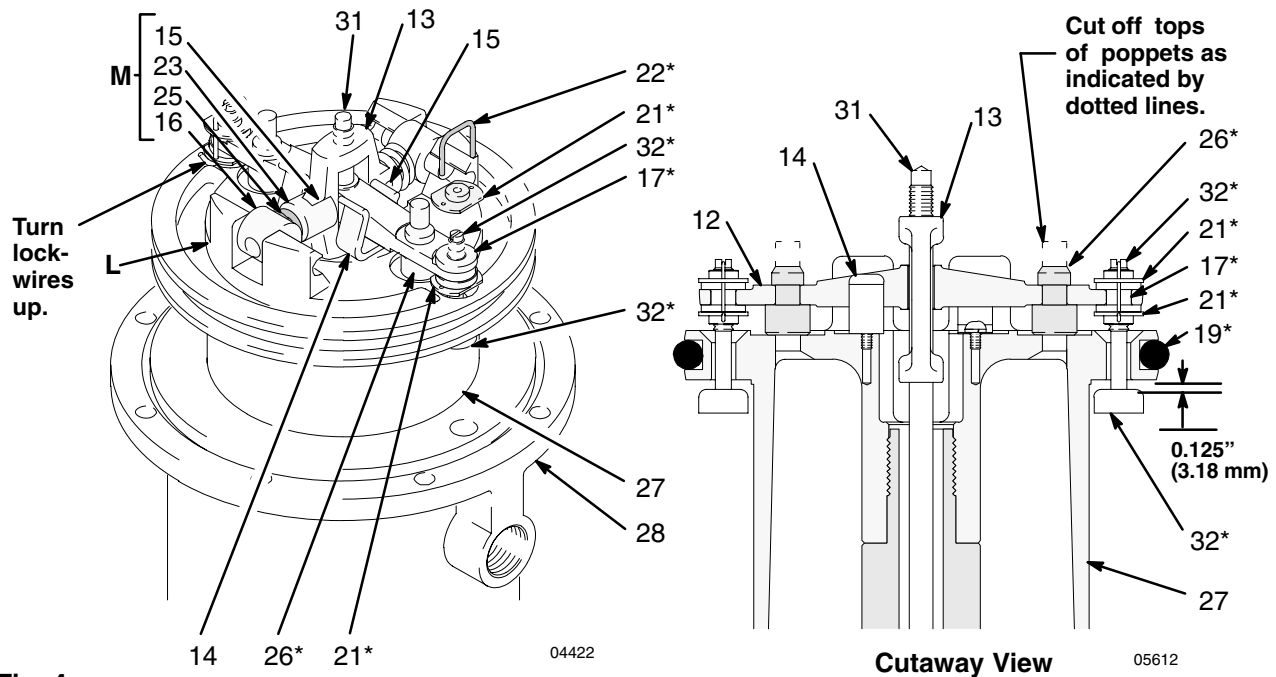

Fig. 4

## Reassembly

1. Place the piston rod (29) flats in the vise with the air motor up.
2. Pull the exhaust valve poppets (26\*) into the valve actuator (12), and clip off the top parts of the poppets (shown with dotted lines in the **Cutaway View** in Fig. 4).
3. Install the lower valve grommets (17\*) in the actuator (12), place the inlet valve poppets (32\*) in the piston, and thread the bottom valve nuts (21\*) onto the inlet valve poppets until there are a few threads left before the threads run out.

**NOTE:** If you thread the valve nuts too far down onto the poppets, they will run off of the threaded part of the poppets.

4. Grease heavily and place the trip rod (31) in the piston, place the actuator (12) in the yoke (13), and place the well-greased actuator/yoke assembly in the piston, with the trip rod going through the center holes of the actuator and yoke and the inlet valve poppets (32\*) going through the lower valve grommets (17\*).
5. Thread the top valve nuts (21\*) onto the inlet valve poppets (32\*) until one thread of the inlet valve poppets is exposed above the valve nuts.
6. Install the toggle pins (15) in the yoke (13), place the toggle arm (23) ends of the toggle assembly (M) onto the toggle pins, and snap the pivot pin (16) ends of the toggle assembly into the lugs (L).

7. Measuring with the gauge (Part No.171818), create 0.125-in. (3.18 mm) of clearance between the inlet valve poppets (32\*) and the piston seat when the inlet valve is open. See the **Cutaway View** Fig. 4.

**NOTE:** Adjust the distance between the inlet valve poppets and the piston seat by turning the top valve nuts (21\*).

8. Tighten the bottom valve nuts (21\*) securely by hand.
9. Align the holes in the valve nuts (21\*) and the slots on the tops of the inlet valve poppets (32\*), and drop the lock wires (22\*) through the holes in the valve nuts and into the slots in the inlet valve poppets. Pull the lock wires down tightly, and bend the ends with pliers so that they cannot be pulled back out of the holes.

## ⚠ CAUTION

Never re-use the old lock wires. They will get brittle and break easily from too much bending. When you install new lock wires, do not bend them too severely, or they may break. See Fig. 4.

10. Grease and install the new o-rings (19\* and 20\*) on the piston assembly (27) and in the groove in the air motor base (28).
11. Clamp the air motor base (28) in a vise horizontally by closing the vise jaws on the flange.

# Air Motor and Throat Service

- Grease and reinstall the seal (2\*) with the lips down, thread the throat bearing (36) into the air motor base (28), and torque the throat bearing to 30 to 40 ft-lb (41 to 54 N.m) using a 1 5/8-in. socket.
- Slide the piston rod (29) down through the packing, and lower the piston assembly (27) into the air motor base (28).
- Carefully lower the cylinder (30) straight down onto the piston assembly (27). Tighten the eight screws (3) that hold the cylinder to the base (28).

## ⚠ CAUTION

To avoid damaging the cylinder wall, lower the cylinder straight down onto the piston. Do not tilt the cylinder while you lower it.

- Grip the trip rod (31) with padded pliers, screw the lift ring (24) onto the trip rod, push the lift ring down, and screw it into the top of the cylinder.
- Install the seal (107\*) with the lips up, and place the seal retainer washer (113) on the piston/valve seat (109). *Make sure the lips of the seal face up.* See Fig. 3.
- Place the piston ball (103) in the displacement

- Clean the threads of the piston/valve seat (109), Apply Loctite® to the threads, and thread the assembly from Step 16 onto the displacement rod (29).
- Clamp the flats of the piston/valve seat (109) in a vise, and torque the displacement rod (29) to the piston valve seat to 45 to 55 ft-lb (61 to 75 N.m).
- Clamp the air motor base (28) in a vise horizontally by closing the vise jaws on the flange
- Thread piston assembly tool (A) (included in repair kit 238751) onto the threads of the displacement pump cylinder (110). See Fig. 5.
- Insert the piston assembly (B) into the displacement pump cylinder.
- Unscrew the piston assembly tool from the displacement pump cylinder. Clip the piston assembly tool with a diagonal cutter (C), and discard it.

**NOTE:** Be careful that you do not scratch the rod.

- Use a strap wrench to screw the displacement pump cylinder (110) to the air motor base (28). See Fig. 3.
- Before you remount the pump, connect an air hose and run the air motor slowly, starting with just enough air pressure to make the air motor run, and make sure that it operates smoothly.
- Reconnect the ground wire before regular operation of the pump.

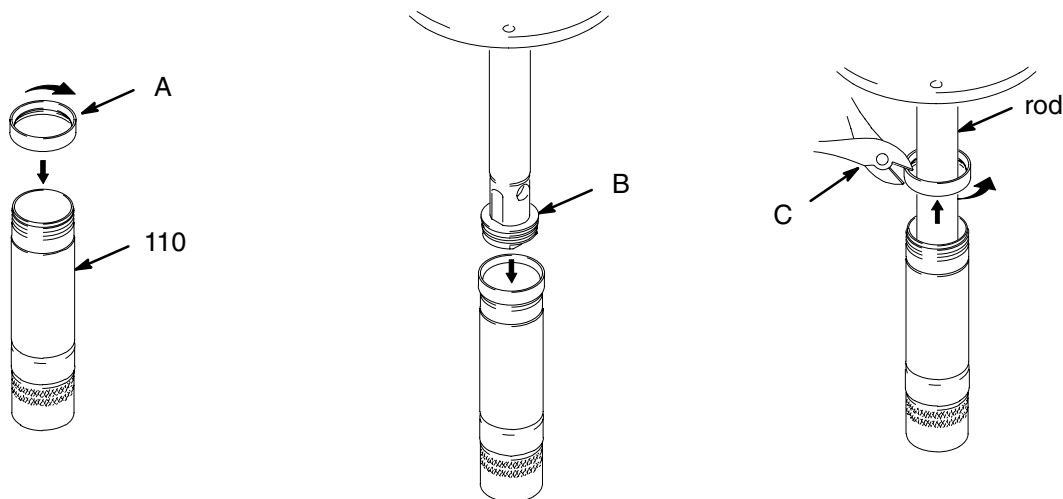

Fig. 5

7221A

# Displacement Pump Service

## Disassembly

**NOTE:** Be sure you have all necessary parts on hand. **Repair Kit 238751** includes repair parts for the air motor and pump. Use all parts in the kit for the best results. Parts included in the kit are marked with one asterisk, for example (19\*), in the text and drawings. See the **Parts List** on page 14.

1. Flush the pump.

### **WARNING**

To reduce the risk of serious injury whenever you are instructed to relieve pressure, always follow the **Pressure Relief Procedure** on page 7.

2. **Relieve the pressure.**
3. Disconnect the hoses, remove the pump from its mounting, and clamp the air motor base (28) in a vise horizontally by closing the vise jaws on the flange.

**Intake Valve.** See Fig 6.

1. **Relieve the pressure.**
2. Unscrew the valve housing (111). Remove the o-ring (105\*), retainer (112), and ball (104).
3. Inspect the parts for wear or damage. If the ball is nicked, replace it. Put grease on the male threads, and reassemble.

**Displacement Pump.** See Fig 6.

**NOTE:** Clean and inspect all parts for wear or damage as you disassemble them. Replace parts as needed. For best results, always replace all the o-rings and packings when you disassemble the pump.

1. **Relieve the pressure.**
2. Follow steps 1 to 7 of **Disassembly** on page 9.
3. Carefully inspect the smooth inner surface of the fluid cylinder (110) for scoring or scratches. Such damage causes premature seal wear and leaking. Replace the cylinder as needed.

## Reassembly

Do steps 16 through 26 in **Air Motor and Throat Service** on page 12.

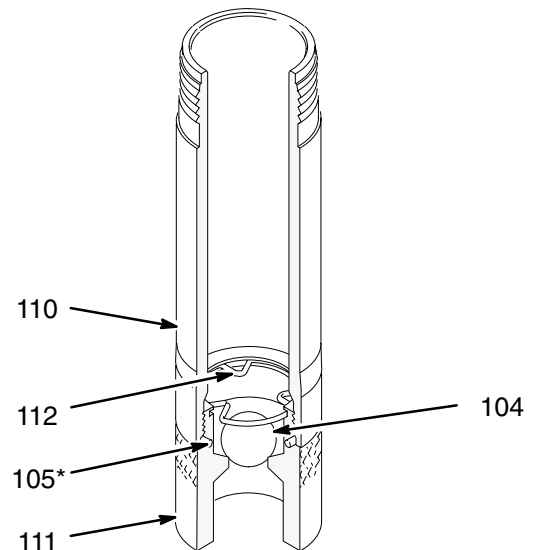

**Fig. 6**

06039

\* Included in Pump Repair Kit 238751, which may be purchased separately. The **Parts List** on page 14 includes all parts in kit.

# Parts List

**Model 205626, Series K**  
Wall-Mount Universal Pump  
Includes items 1 to 113

**Model 222065, Series C**  
55-Gallon Drum Cover-Mount Pump  
Includes items 1 to 113, 150, and 151

**Model 222095, Series C**  
55-Gallon Drum Bung-Mount Pump  
Includes items 1 to 113, 150, 152, and 153

Model 205626, Series K				Model 222065, Series C				Model 222095, Series C			
Ref No.	Part No.	Description	Qty.	Ref No.	Part No.	Description	Qty.	Ref No.	Part No.	Description	Qty.
1		AIR MOTOR ( <i>items 2 to 36</i> )	1	30	15E954	CYLINDER, air motor	1				
2*	110247	SEAL; polyurethane, nitrile	1	31	207150	ROD, trip	1				
3	101578	SCREW, cap, hex hd	8	32*	236079	POPPET, inlet valve	2				
5	102656	MUFFLER, air exhaust	1	33	119344	LABEL, designation	1				
7	116343	SCREW, ground	1	35▲	290259	LABEL, warning	1				
11	156698	PACKING, o-ring	1	36	191546	BEARING, throat	1				
12	158359	ACTUATOR, air valve	1	103	100279	BALL; sst	1				
13	158360	YOKE, trip rod	1	104	101190	BALL; sst	1				
15	158362	PIN, toggle	2	105*	156633	PACKING, o-ring	1				
16	158364	PIN, pivot	2	107*	113564	SEAL, block, vee	1				
17*	158367	GROMMET, lower valve	2	108*	156641	PACKING, o-ring	1				
18	158377	PACKING, ring seal	1	109	191547	PISTON/VALVE SEAT	1				
19*	158378	PACKING, o-ring	1	110	191548	CYLINDER, fluid	1				
20*	158379	PACKING, o-ring	1	111	183009	VALVE HOUSING	1				
21*	160261	NUT, valve	4	112	157182	RETAINER, ball	1				
22*	160618	WIRE, lock	2	113	191123	RETAINER, seal	1				
23	160623	ARM, toggle	2	150	110127	SPACER, foot	1				
24	190929	RING, lift	1	151	191128	TUBE, extension; 21.75" (553 mm)	1				
25	167585	SPRING, helical compression	2	152	191130	TUBE, extension; 26.0" (661 mm)	1				
26*	170709	POPPET, exhaust valve	2	153	222308	BUNG ADAPTER	1				
27	207391	PISTON, includes items 27a to 27c, (also includes 207385 repair kit when ordered as a replacement part)	1								
27a	102975	SCREW, rd hd mach; 6-32 X 1/4"	2								
27b	158361	CLIP, spring	2								
27c		BARE PISTON ( <i>not sold separately</i> )	1								
28	191544	BASE, air motor	1								
29	191545	ROD, displacement	1								

\* *Included in Repair Kit 238751, which may be purchased separately.*

▲ *Extra warning labels are available at no cost.*

# Parts Drawing

1 Torque to 30 to 40 ft-lb  
(41 to 54 N.m)

2 Torque to 45 to 55 ft-lb  
(61 to 75 N.m)

3 Lips face down

4 Lips face up

5 When assembling the fluid cylinder  
(110) over the assembled fluid  
piston (107, 109, 113), use the  
piston assembly tool included in  
repair kit 238751 and steps 21  
through 23 on page 12 .

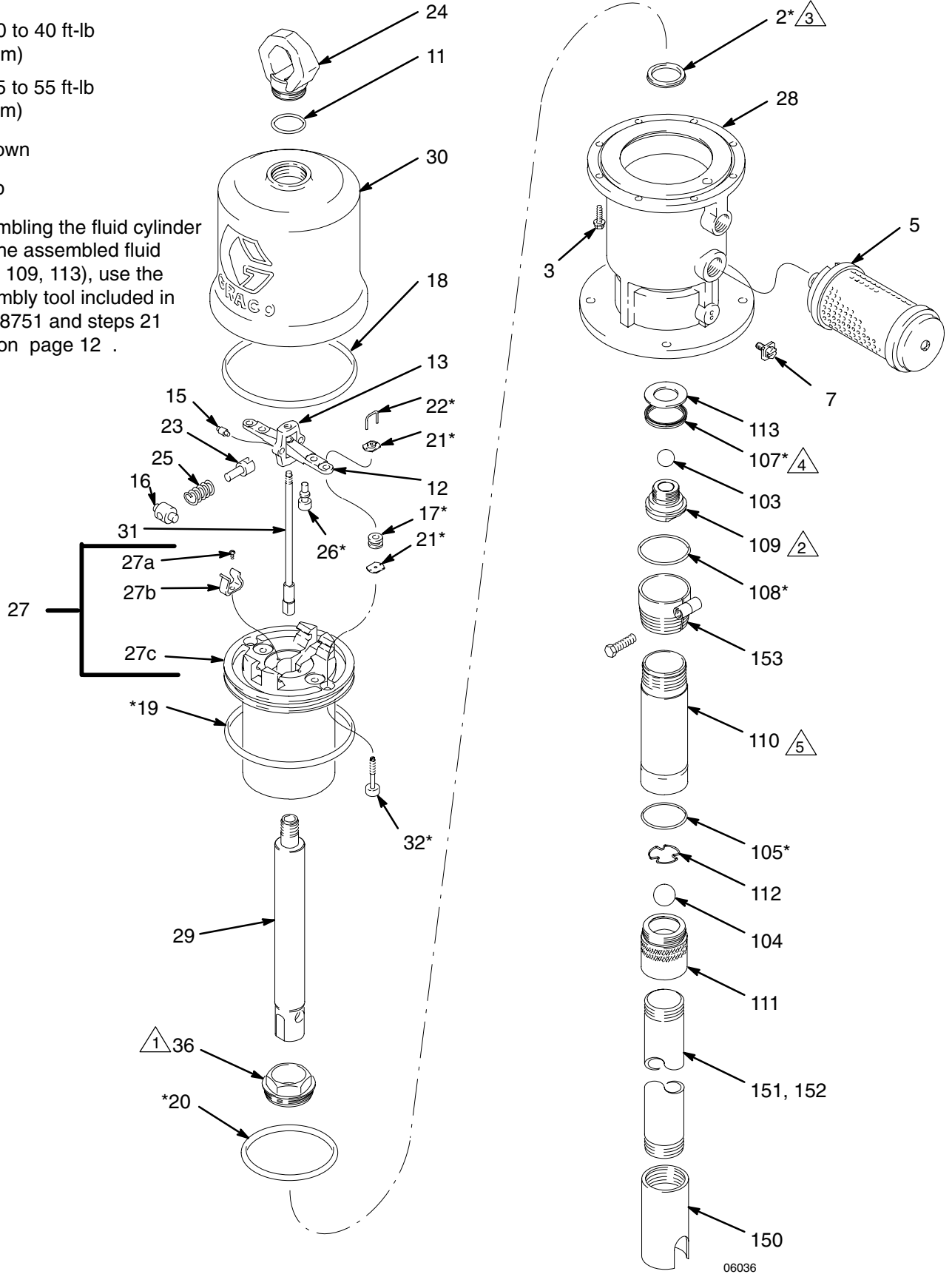

# Dimensions

MODEL 205626, Series K

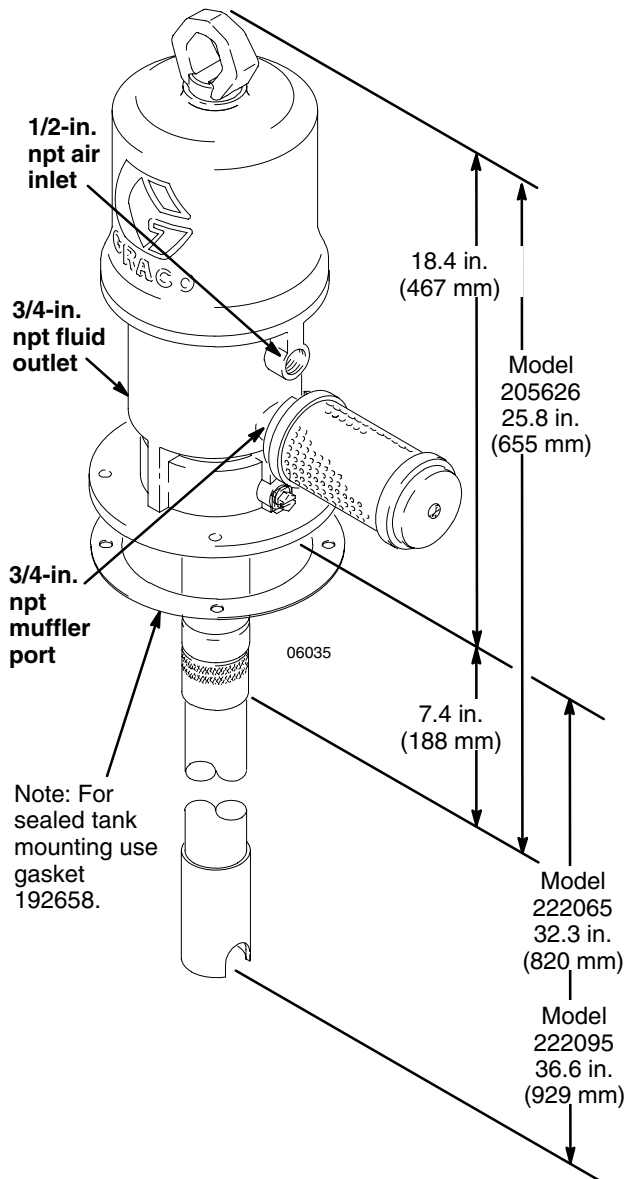

# Mounting Hole Layout

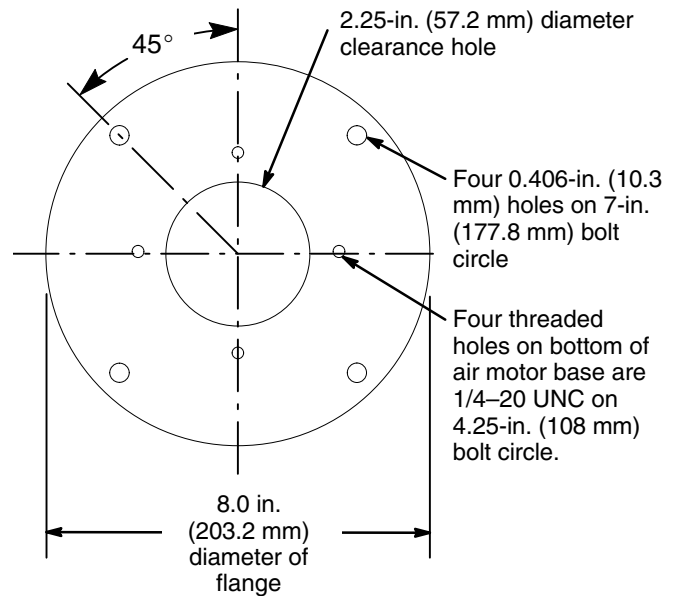

# Technical Data

Maximum working pressure	1800 psi (124 bar)
Fluid pressure ratio	10:1
Air operating range	40 to 180 psi (2.8 to 12.4 bar)
Air consumption	Approximately 13 ft <sup>3</sup> /min per gallon pumped, (6 m <sup>3</sup> /hour per liter pumped) at 100 psi (6.9 bar)
Pump cycles per gallon (liter)	20 (5.3)
Maximum recommended continuous pump speed	60 cycles/min; 3 gpm (11.4 liter/min)
Recommended speed for optimum pump life	15 to 25 cycles per min
Sound data	78.0 dBA sound power at 100 psi air, 40 cycles per minute
Piston seals	polyurethane with nitrile spreader
Rod seals	polyurethane with nitrile spreader
Wetted parts	aluminum, steel, polyurethane, nitrile
Weight (Model 205626, Universal Pump)	28.7 lb (13.0 kg)

*Loctite® is a registered trademark of the Loctite Corporation.*

# Performance Chart

**KEY** black curves=fluid outlet pressure  
gray curves=air consumption

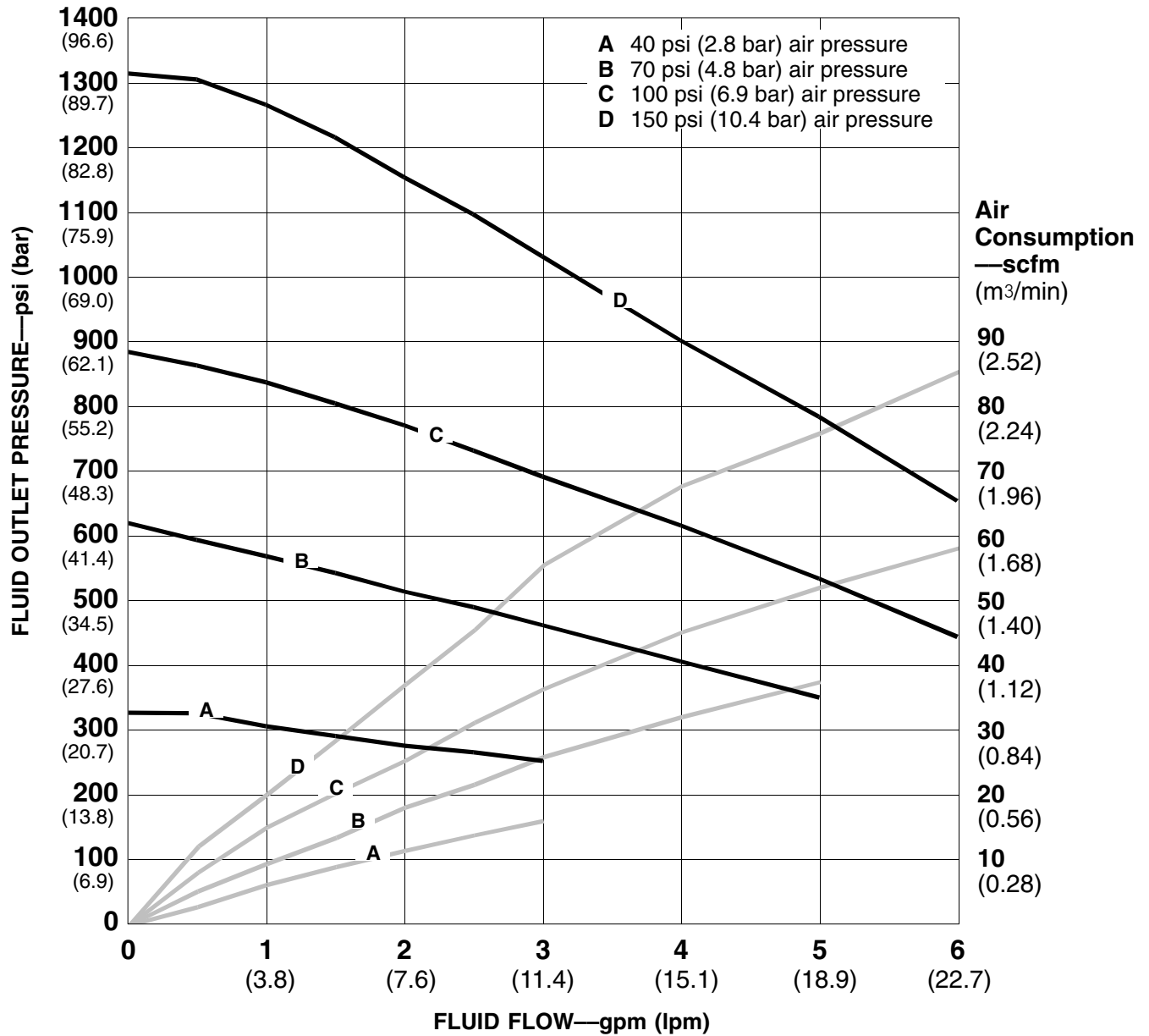

Test Fluid: 10-weight oil at 75° F (23.9° C)

**To find fluid outlet pressure** at a specific fluid flow and operating air pressure:

1. Locate desired fluid flow along bottom of chart.
2. Follow vertical line up to intersection with selected fluid outlet pressure curve (black).
3. Follow left to scale to read fluid outlet pressure.

**To find pump air consumption** at a specific fluid flow and air pressure:

1. Locate desired flow along bottom of chart.
2. Read vertical line up to intersection with selected air consumption curve (gray).
2. Follow right to scale to read air consumption.

# Graco Standard Warranty

Graco warrants all equipment manufactured by Graco and bearing its name to be free from defects in material and workmanship on the date of sale to the original purchaser for use. With the exception of any special, extended, or limited warranty published by Graco, Graco will, for a period of twelve months from the date of sale, repair or replace any part of the equipment determined by Graco to be defective. This warranty applies only when the equipment is installed, operated and maintained in accordance with Graco's written recommendations.

This warranty does not cover, and Graco shall not be liable for general wear and tear, or any malfunction, damage or wear caused by faulty installation, misapplication, abrasion, corrosion, inadequate or improper maintenance, negligence, accident, tampering, or substitution of non-Graco component parts. Nor shall Graco be liable for malfunction, damage or wear caused by the incompatibility of Graco equipment with structures, accessories, equipment or materials not supplied by Graco, or the improper design, manufacture, installation, operation or maintenance of structures, accessories, equipment or materials not supplied by Graco.

This warranty is conditioned upon the prepaid return of the equipment claimed to be defective to an authorized Graco distributor for verification of the claimed defect. If the claimed defect is verified, Graco will repair or replace free of charge any defective parts. The equipment will be returned to the original purchaser transportation prepaid. If inspection of the equipment does not disclose any defect in material or workmanship, repairs will be made at a reasonable charge, which charges may include the costs of parts, labor, and transportation.

**THIS WARRANTY IS EXCLUSIVE, AND IS IN LIEU OF ANY OTHER WARRANTIES, EXPRESS OR IMPLIED, INCLUDING BUT NOT LIMITED TO WARRANTY OF MERCHANTABILITY OR WARRANTY OF FITNESS FOR A PARTICULAR PURPOSE.**

Graco's sole obligation and buyer's sole remedy for any breach of warranty shall be as set forth above. The buyer agrees that no other remedy (including, but not limited to, incidental or consequential damages for lost profits, lost sales, injury to person or property, or any other incidental or consequential loss) shall be available. Any action for breach of warranty must be brought within two (2) years of the date of sale.

Graco makes no warranty, and disclaims all implied warranties of merchantability and fitness for a particular purpose in connection with accessories, equipment, materials or components sold but not manufactured by Graco. These items sold, but not manufactured by Graco (such as electric motors, switches, hose, etc.), are subject to the warranty, if any, of their manufacturer. Graco will provide purchaser with reasonable assistance in making any claim for breach of these warranties.

In no event will Graco be liable for indirect, incidental, special or consequential damages resulting from Graco supplying equipment hereunder, or the furnishing, performance, or use of any products or other goods sold hereto, whether due to a breach of contract, breach of warranty, the negligence of Graco, or otherwise.

## **FOR GRACO CANADA CUSTOMERS**

The parties acknowledge that they have required that the present document, as well as all documents, notices and legal proceedings entered into, given or instituted pursuant hereto or relating directly or indirectly hereto, be drawn up in English. Les parties reconnaissent avoir convenu que la rédaction du présente document sera en Anglais, ainsi que tous documents, avis et procédures judiciaires exécutés, donnés ou intentés à la suite de ou en rapport, directement ou indirectement, avec les procédures concernées.

# Graco Phone Number

**TO PLACE AN ORDER**, contact your Graco distributor, or call this number to identify the distributor closest to you:

**1-800-533-9655 Toll Free**  
**612-623-6928**  
**612-378-3590 Fax**

*All written and visual data contained in this document reflects the latest product information available at the time of publication. Graco reserves the right to make changes at any time without notice.*

This manual contains English. MM 308655  
**Graco Headquarters:** Minneapolis  
**International Offices:** Belgium, Korea, China Japan

**GRACO INC. P.O. BOX 1441 MINNEAPOLIS, MN 55440-1441**  
308655 06/1996 Revised 3/2007